

Hello, I'm

HECTOR ARTURO SALAZAR

Product & Industrial Designer,
Design Leader & Educator



WHO I AM



A Creative, data-driven and commercially astute Industrial & Product Design leader and Educator with 20 years of experience in leading end-to-end conception, design and development of a wide variety of deliverables for products. Known for synthesizing data from market and design research and business context to drive a design-led product roadmap. With a strong focus on human-centred design, circular design and sustainability.

SKILLS

Product Design. Directed efforts in producing creative, innovative, cost-effective, reproducible, scalable and sustainable products. I managed the end-to-end process from concept generation to final presentation and manufacturing. I am defining product vision and roadmap with clarity, time and cost.

Project Management. Provided direction and oversight for complex projects and ensured the integrity of multiple project delivery plans concerning time, budget, scope, change, risk and resources.

Technical Skills. MS Office Suite; AutoDesk AutoCAD; AutoDesk Inventor; 3D Studio Max; Rhinoceros; Adobe Photoshop; Adobe Illustrator; Audio Edition – Vegas; Video Edition – Premiere, Vegas; Web Tools – Dreamweaver, HTML, CSS; Animation – Flash, Blender; Rendering – Keyshot; VR & AR – Unity; Moodle; MS Teams.



RESEARCH & MENTORED GUIDED PROJECTS

Ascertain research context and requirements based on research objectives, Collecting data on consumers, competitors and market conditions using quantitative and qualitative research methods.

Research Tutor, Assisting students with research, preparation, and other academic tasks during their Final Major Project to obtain the BA (Honors) in Product Design Awarded by Coventry University (UK).

Research Experience

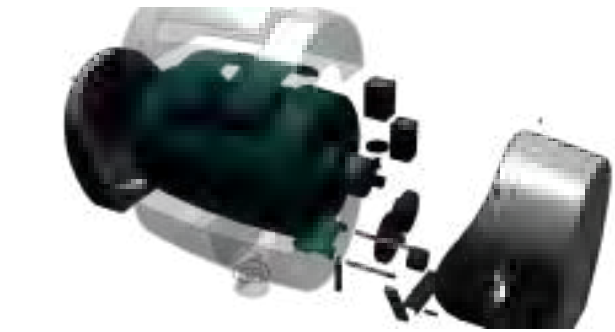

Kneer: Link tutor Award 2017 by Devi Ramanathan



AEROz: First Class, Coventry Student by Ikheon Choi

2016 Singapore Good Design Mark Project: Safety No. 1, First Aid Furniture By Alexandrea TENG Xiang Yi

Awards Art for Everyday 2012 Project: Ex-presso By Felicia Gomedí



KODO: Link tutor Award 2018 by Leon Faust



D'Star Design Award 2013 Project: Vdesk by LEE Yong Ju



Final Presentation March 2019 Major Project Design



KUJIWARA: Link tutor Award 2021 by Nguyen Tran Cat Tuong

Research Experience



Volvo for life Design Awards 2007



IKEA Singapore's Young Designer Award 2016 Project: Grow



IKEA Singapore's Young Designer Award 2015 Project: VÄN

2016 Singapore Good Design Mark Project: Otagon Furnace by Wayne GOH Keh Yeng

IKEA Singapore's Young Designer Award 2016 Project: Grow by Wayne GOH Keh Yeng

D'Star Design Award 2013 Project: Kory by Ananda Annisa PRASETYANTO



2010 Best Project: Major Project "Sustainable Shoe" by Rohan Joglekar



D'Star Design Award 2013



2016 Singapore Good Design Mark



TALKS & WORKSHOPS

I developed and delivered talks and workshops to promote the Product Design Discipline through interesting creations of products that the participants can do and take home.

Talks and Workshops



Talk and Workshops in Chengdu, China, promoting the Product Design Programme. PS-One China organized this event.

Talks and Workshops



Talk and Workshops in Chengdu, China, promoting the Product Design Programme. Rosso China organized this event.

Talks and Workshops



Design Thinking in Product Design Workshop for Winstedt School students.

Talks and Workshops



Workshops to promoting the Product Design Programme.



CAREER EXPERIENCE

My professional achievements demonstrate the leadership, expertise and commitment I will bring to the job. My experiences, transferrable skills and professionalism will be a welcome addition to your organisation.

One Holland Village - Public Art Furniture Design Competition



Taikaha



Simple functional and modular chair, thinking in sustainability, uses the minimum part components to reduce the cost of mass production and the footprint.

The left side is the same as the right side, allowing one mold to produce several pieces; the central pipe is simple and holds all the parts attached by screws and nuts.

Being suspended in the air allows the body to have better adaptation.



Lion Cup Coaters



Decorative gift Lion cup coaters made of wood and felt.

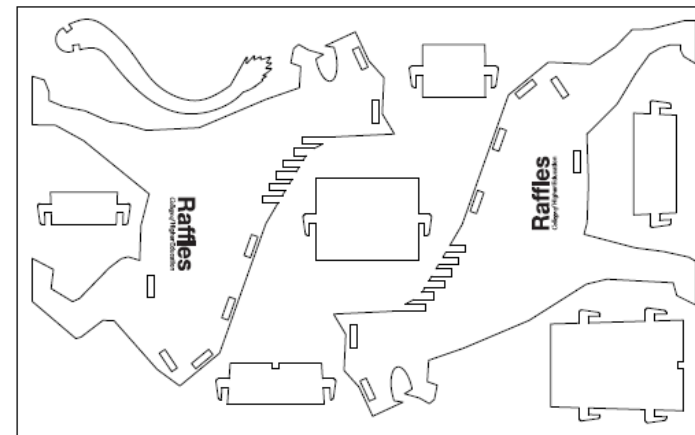

F1 Car Toy



Inspired by F1 Car and laser cutting machine,
I develop this car for a training and playful race.

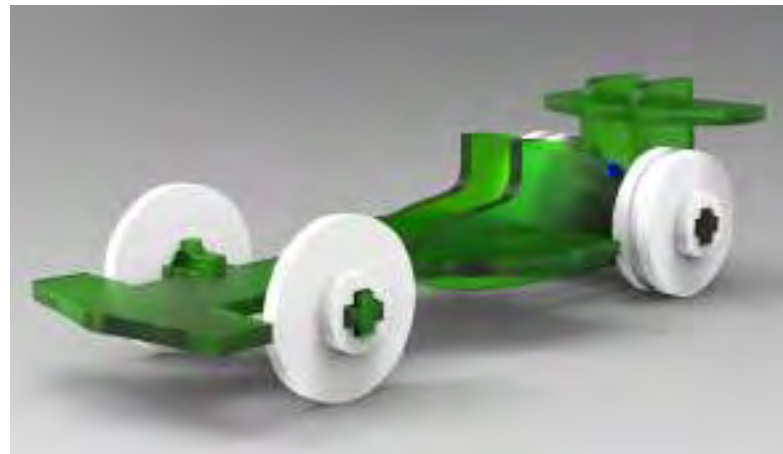
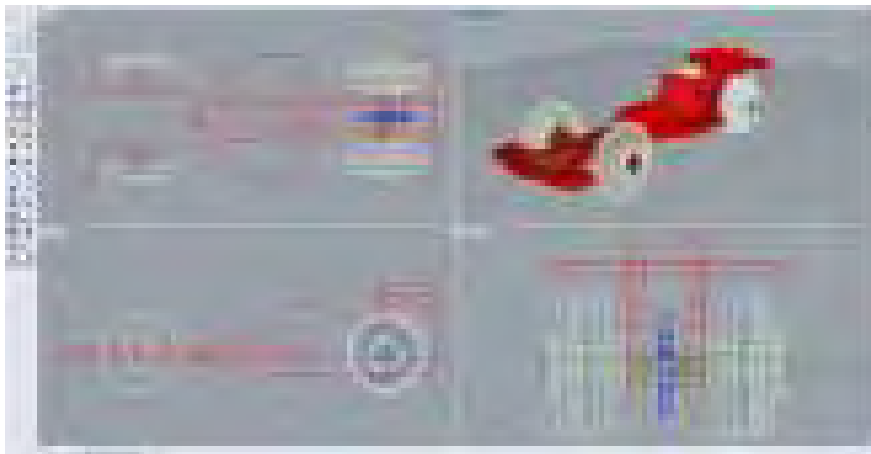
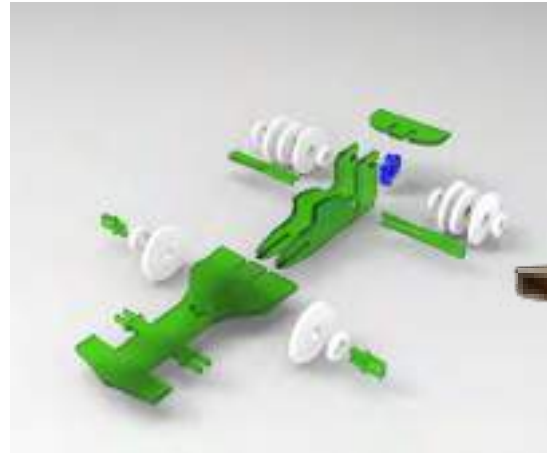
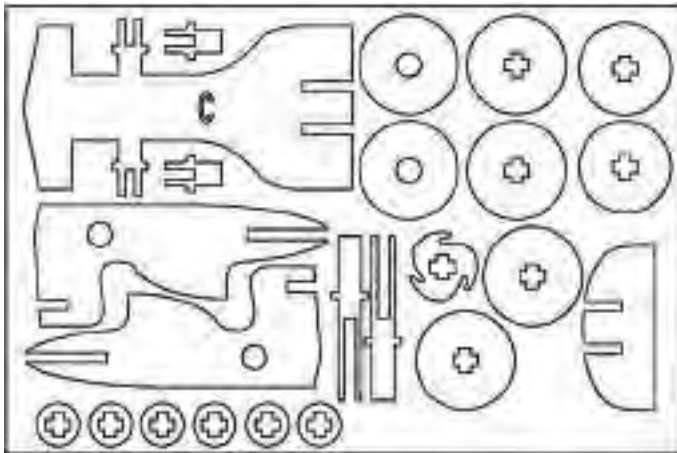

F1 Car Toy



Projects SysGold



Design of a system that helps in the process of digitization of official documents for banking registration.(2005)

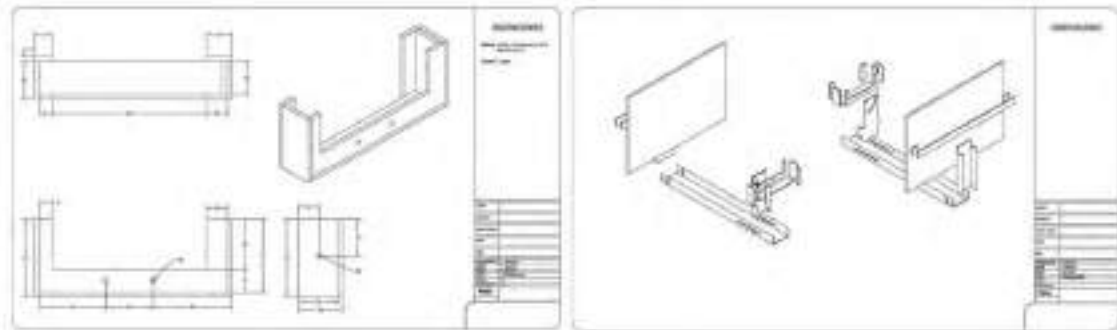
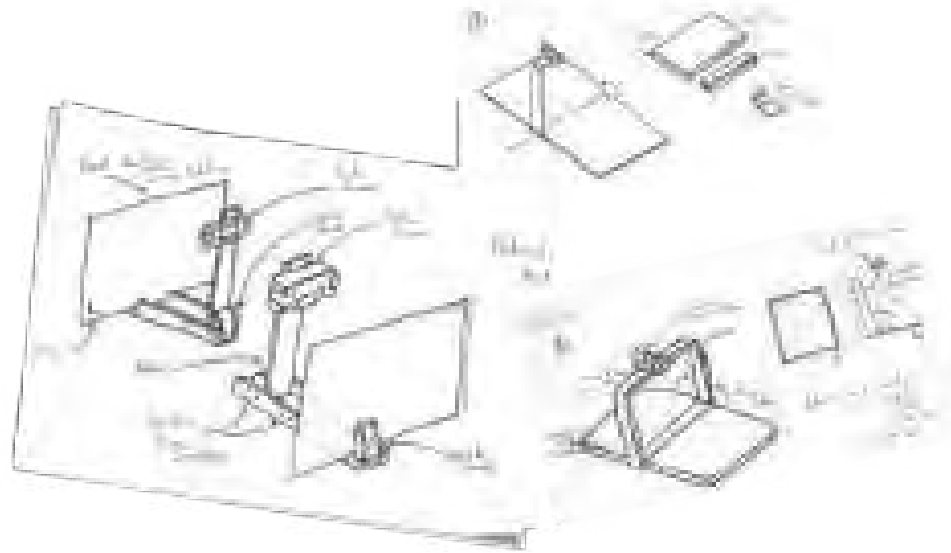

Sobrero (Hat)



Sobrero - Glass Rimmer in Thermoforming for a promotional Squirt soda campaign in Mexico (2002)

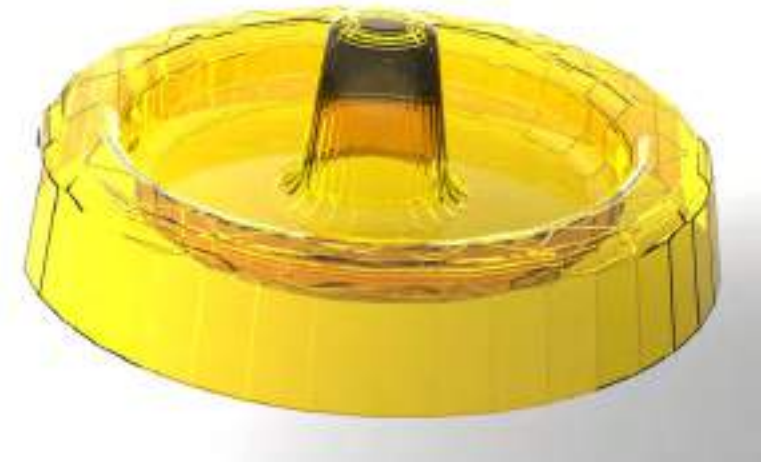



Develop of stand - Point of sale for Bimbo Group Mexico (2008)



Pierdant



Design and develop various promotional products for different companies and campaigns. Mexico (2002)



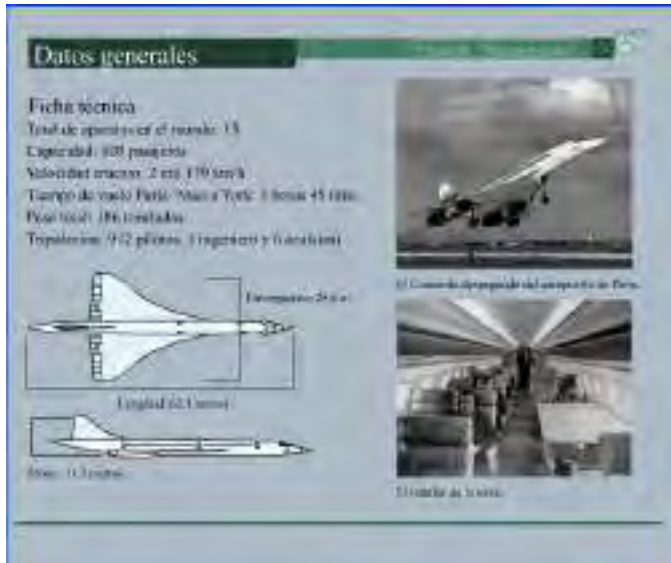

Designed and developed the interface for the Reforma.com site in 2000 and supervised the flash animation infographics.



Design of an information kiosk for Michelin, development of the interactive and design of the leaflets for the Michelin point of sale within the Sam's Club stores. Mexico (2001)



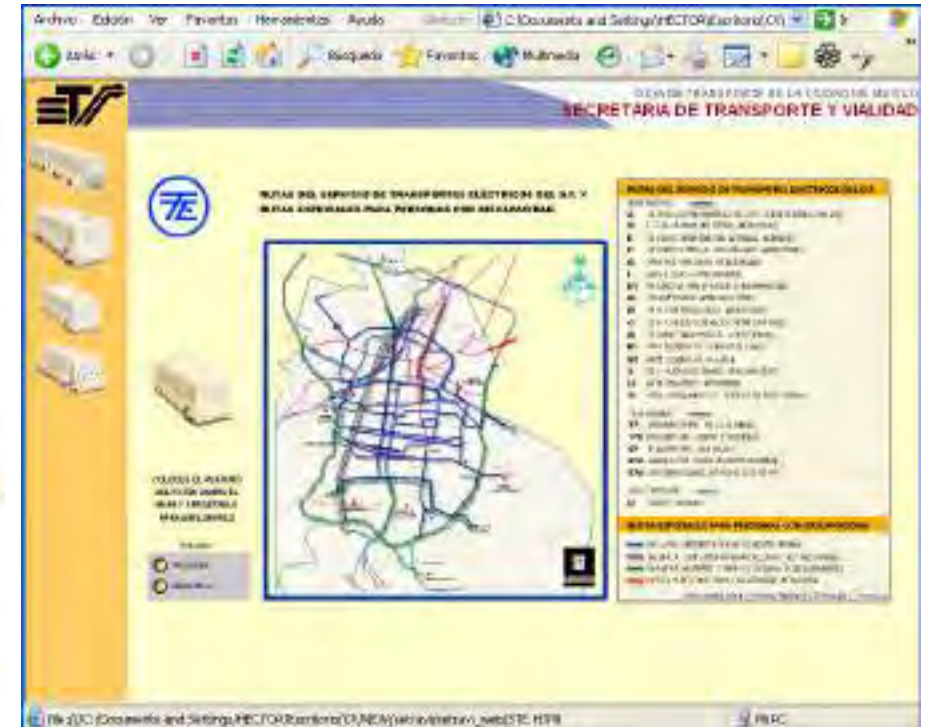

Develop and design the Posters for Public transport and create pocket guide maps for SETRAVI (Secretary of Transportation and Roads) Mexico City (2001)



Designed and developed the interface for the Elec2003, IFE, the intranet portal for providing capacitation and information relative to the national election in Mexico in 2002. Guide a 5-member staff team to train users on the interface at the national level.



Interactive design for the Ibero-American Meeting and the first International Congress on the valuation and management of heritage cemeteries and funerary art carried out in Mexico City and Morelia.

BRANDING



Design of Image, Label and Packaging for raw and derivatives of Nopales (cactus) and design of the bottles for the nopal jam. Mexico (1999)

BRANDING - Developed for Acid Digital



Inkburrow

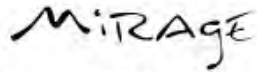

Manufacturera Mirage S.A. de C.V.

Myriad

■ Azul Pantone 2746 C

■ Rojo Pantone Red 032 C

■ Negro Pantone Black C



- Develop the Corporate image of the company Mirage.
- Image and Packaging Design for the company CONOBA for their product of Strawberry Crush (Irapuato, Guanajuato, Mexico - 2004).

BRANDING



- Image and Label Design for Godoy Winery – Argentina (2001).
- Redesign the Label of the product of coffee for the company Tapachulteco. Chiapas, Mexico (2000)



INDUSTRY COLLABORATIONS

Leeds works alongside diverse students to lead collaborative studios and capture opportunities to work with industry partners to generate imaginative, feasible solutions to real-world design challenges.

Paragon Shopping Centre & Embassy of Switzerland, Fashion Cow.



Adoption of 5 “Fashion Cows” in celebration of 50 years of diplomatic relations between Switzerland and Singapore. Students curated design for these “Fashion Cows” with proceeds to be donated to The Business Times Budding Artists’ Fund (BT BAF).



Paragon Shopping Centre, Flight to Fantastico.



A celebration of the bilateral ties between Singapore and Latin America through conceptualisation, production and embellishment of 3D printed macaws by the Raffles Jewellery Designers.



Raffles x RISIS Official Jewellery Design Collaboration.



Worked with renowned Singaporean brand of uniquely fashioned, orchid inspired jewellery and sculptures to provide students with opportunity to participate in design challenges for the brand.



Singapore Tourism Board, Temasek Suite F1 Car x Raffles Design Institute.



Designed an F1 cardboard car displayed at the VIP Temasek Suite for the 2014 Singapore Grand Prix. Coordinated students' product design, concept and materialisation.

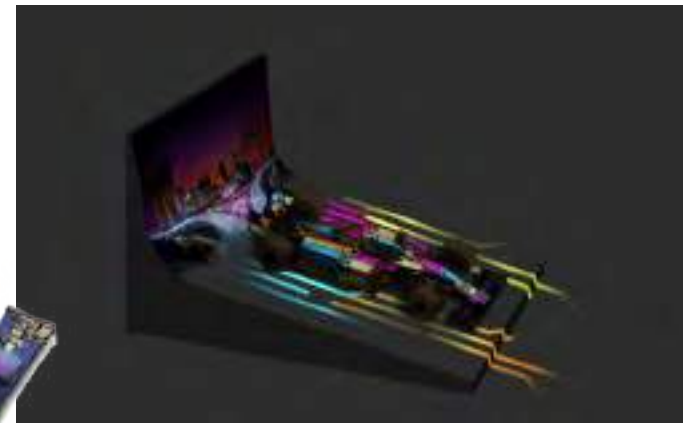

Singapore River One (SRO), Parklet Urban Furniture.



Pilot trial to revitalise streetscape along Circular Road by replacing carpark spaces with decorative fixtures as part of long-term plan of street pedestrianisation. Multi-department collaboration with students from Interior Design, Product Design and Visual Communications.

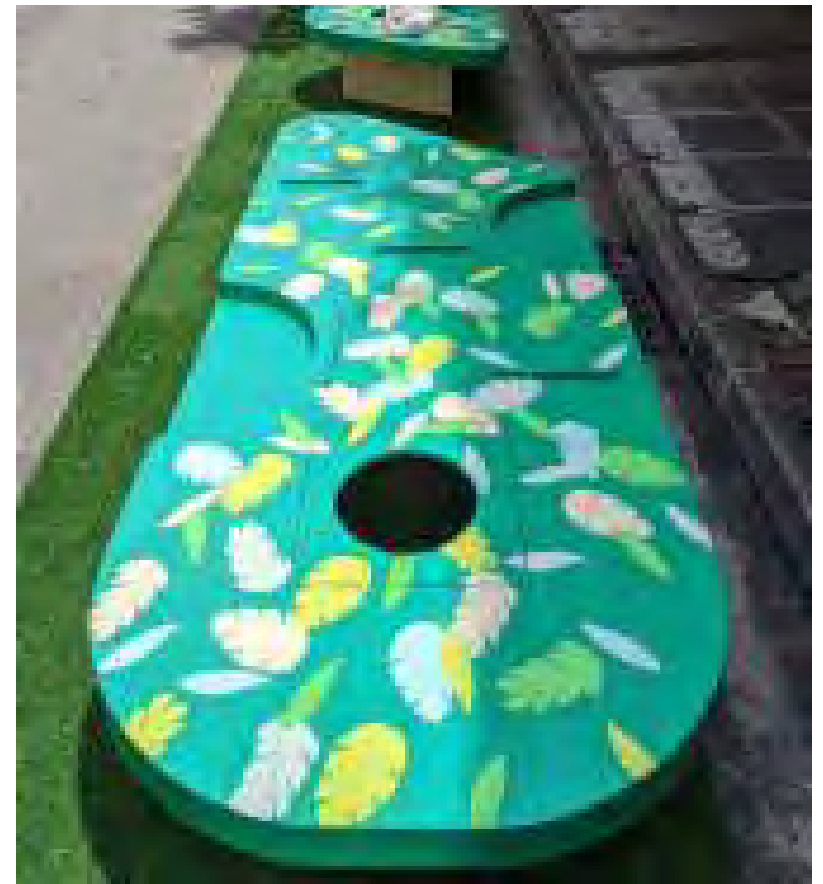

iLight Marina Bay, Passage of Inner Reflection.



Annual light showcase featuring artists from Singapore and around the world with design focus on energy-saving lighting and environmentally-friendly materials.



Designed by CAO Lunle



Pandastic! Design Competition



In this light art design competition, the panel of judges has selected the top five designs from Raffles Design Institute to be installed around River Wonders.



By Tan Lindsay



By Abigail Natania Soelisyo



By Yang Kunlin



By Li Xiaozhang



By Wong Leke



Communal Dining – Celebrating Singapore’s Hawker Culture



Celebrating the Hawker Culture of Singapore, an element on the UNESCO Representative List of the Intangible Cultural Heritage of Humanity, Raffles Design Institute is proud to present to you a feast for your senses with our unique takes of Singapore’s Hawker Culture through Fashion Design and Marketing, Jewellery Design, Product Design, Graphic Design, and Interior Design.



PHOTOGRAPHY

A black and white photograph of a man wearing a cap and a jacket, holding a large camera with a long lens up to his eye. He is standing on a stone wall, looking out over a valley with a river and mountains in the background. The scene is captured in a cinematic style with soft lighting.

The camera is like a sketchbook that helps me record special events, people, and memories of my travels, meet new people and offer many possibilities for creative expression and technical expertise.

Photography adds value to our lives while helping us learn and grow. Allowing us to share our life and experiences meaningfully, engage and have fun with others.

Photography Work



I use one of these two cameras for most of my photography: the Sony Alpha DSLR-A100 and the DSLR-77ii.

Photography Work



Photography Work

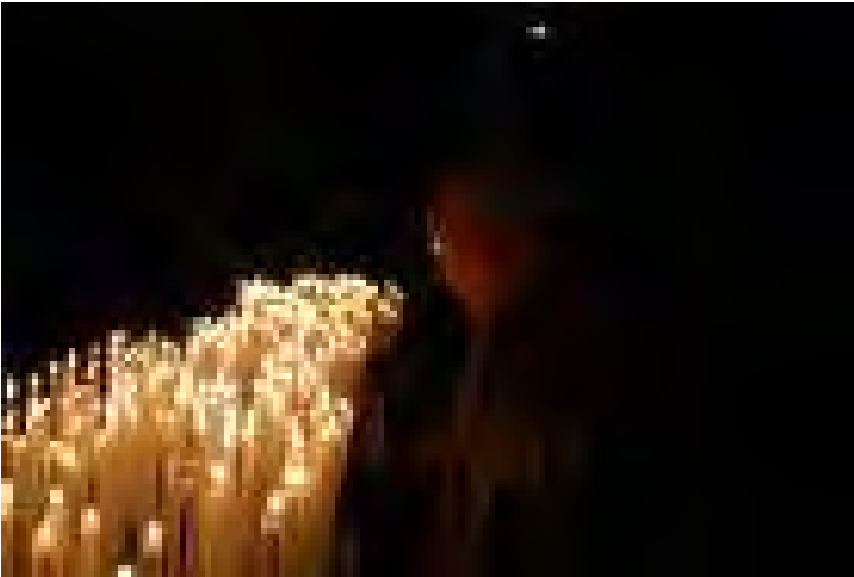

CONTACT



Thanks for your attention and time; I would like to speak with you about any possible prospect.

Sincerely,

Hector Arturo Salazar Navarrete

hectorsalazardesign@outlook.com

+65 8111 9529

<https://www.linkedin.com/in/hectorsalazardesign/>